

Assembly and Installation Guide
Series 6200/6500 Vinyl Sliding Patio Doors

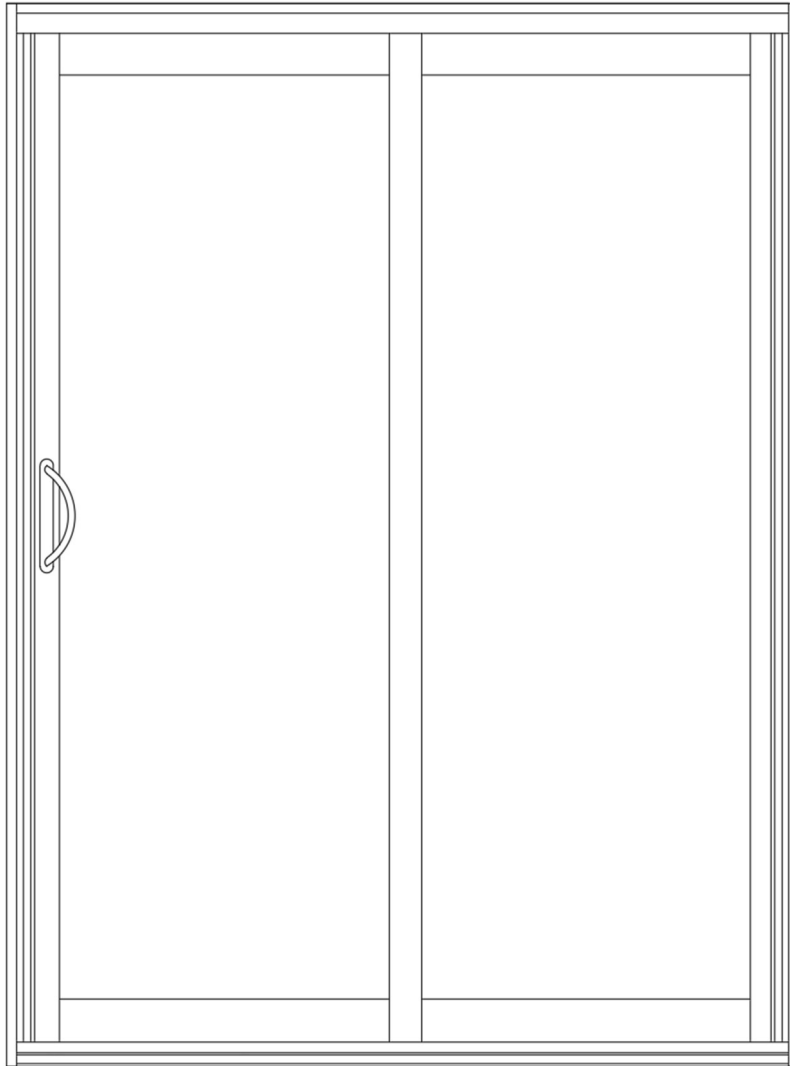

Outside View Elevation

NOTICE

READING THESE INSTRUCTIONS FIRST AND FOLLOWING THE PROCEDURES IN PROPER SEQUENCE WILL REDUCE COSTLY MISTAKES AND WASTED TIME.







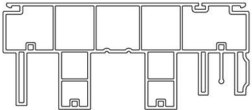

	Main Frame Header 6200 Series Vinyl frame extrusion. Used for the header.	1 Pc		#8X2" Pan Head Washer Screws For main frame assembly.	16 Pcs
				#8X3" Pan Head Washer Screws Frame Installation	12 Pcs
	Main Frame Jamb 6200 Series (Left and Right) Vinyl frame extrusion. Used for the jambs (left and right sides). Includes foam gaskets	1 Set		#8x1-1/4" Pan Head Screws To secure fixed panel bumper to the jamb. 4 Screws used to attach the fixed panel clips to the main frame making it stationary.	4 Pcs
	Main Frame Sill Vinyl frame extrusion. Used for the sill threshold.	1 Pc		#8x3/4" Self-Drilling Screws To Secure fixed panel bumper to the fixed panel. 4 Screws used to attach fixed panel clip to fixed panel.	4Pcs
	Main Frame Header 6500 Series Vinyl frame extrusion with wood buck. Used for the header	1 Pc		Screw Caps The screw caps are installed on all screws used on the fixed panel bumper.	8 Pcs
	Main Frame Jamb 6500 Series (Left and Right) Vinyl frame extrusion with wood buck. Used for the jambs (left and right sides). Includes foam gaskets.	1 Set		Fixed Panel Bumper The fixed panel bumper is installed at the top and bottom of the fixed panel. Adjacent to the left of right ramb dependent on the operation of the door.	2 Pcs
	Mortise Lock Handle & Keeper - STANDARD Interior & exterior handle, keeper allows operating frame to lock with main frame. Hardware bag included.	1 Set		Anti-Lift Block with #8x3/4" Pan Head Self Drilling Screw The anti-lift block is installed in the header portion of the door frame above the operating panel where the two panels interlock.	1Pc 2Pcs
				Sill Pad Install the sill pad tightly against the installed fixed panel and directly against the panel support. Seal perimeter of the sill pad with silicone sealant.	1 Pc

Table 1

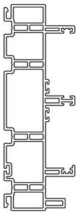
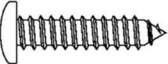
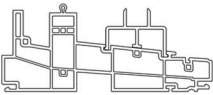
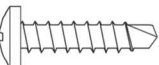
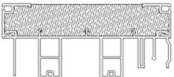
2-PANEL DOOR – INSTALLATION INSTRUCTIONS

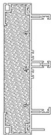
GENERAL: Door elevations shown in these instructions are as viewed from the outside.

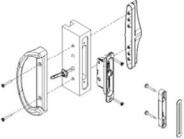

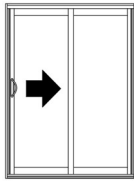
"XO" DOOR

'X' denotes the active or operating panel(s).

'O' denotes the inactive or fixed panel(s).

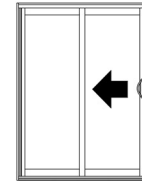

"OX" DOOR

All 2-panel doors between 72" to 80" high are fully reversible. The locking hardware on the operating panel is located at the mid-point of the panel unless otherwise requested. For 3 and 4 panel doors or alternate locking hardware options, refer to supplemental instructions sheet.

A) ROUGH OPENING PREPARATION:

The rough opening should be made 3/4" wider and 3/8" higher (+/- 1/8" each way) than the actual door frame size (Refer to the chart for frame sizes). The sill or base of the opening must be solid, level and of sufficient width and depth to support the entire door sill in a continuous and uniform manner. If installing door directly on concrete base; wood blocking (1"x6" strapping) should be used between the sill threshold and concrete base to eliminate thermal transfer. Increase clear openings height to accommodate any sill strapping or shimming. It is important that the opening be plumb and square as the door will not perform to its potential if installed into an improperly prepared opening.

6000/6500 Series Technical Specifications

Configuration	Size	6200 & 6500 Series Frame Size (in)				Rough Opening			
		Width	Height 6'8"	Height 6'10"	Height 8'0"	Width	Height 6'8"	Height 6'10"	Height 8'0"
XO or OX	5068 (5080)	59 1/4	79 5/8	81 1/2	95	60	80	81 7/8	95 3/8
XO or OX	5868	58 5/8	79 5/8	81 1/2	N/A	59 3/8	80	81 7/8	N/A
XO or OX	6068 (6080)	71 1/4	79 5/8	81 1/2	95	72	80	81 7/8	95 3/8
XO or OX	6868	70 5/8	79 5/8	81 1/2	N/A	71 3/8	80	81 7/8	N/A
XO or OX	8068 (8080)	95 1/4	79 5/8	81 1/2	95	96	80	81 7/8	95 3/8
XOO or OOX	7668 (7680)	86 5/8	79 5/8	81 1/2	95	87 3/8	80	81 7/8	95 3/8
XOO or OOX	9068 (9080)	104 5/8	79 5/8	81 1/2	95	105 3/8	80	81 7/8	95 3/8
XOO or OOX	12068 (12080)	140 5/8	79 5/8	81 1/2	95	141 3/8	80	81 7/8	95 3/8
OXO	7668 (7680)	88 3/8	79 5/8	81 1/2	95	89 1/8	80	81 7/8	95 3/8
OXO	9068 (9080)	106 3/8	79 5/8	81 1/2	95	107 1/8	80	81 7/8	95 3/8
OXO	12068 (12080)	142 3/8	79 5/8	81 1/2	95	143 1/8	80	81 7/8	95 3/8
OXXO	10068 (10080)	116 1/2	79 5/8	81 1/2	95	117 1/4	80	81 7/8	95 3/8
OXXO	12068 (12080)	140 1/2	79 5/8	81 1/2	95	141 1/4	80	81 7/8	95 3/8
OXXO	12069 (12080)	188 1/2	79 5/8	81 1/2	95	189 1/4	80	81 7/8	95 3/8

Table 2

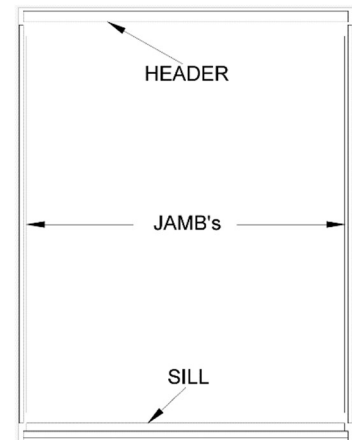
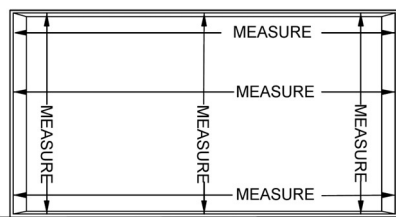
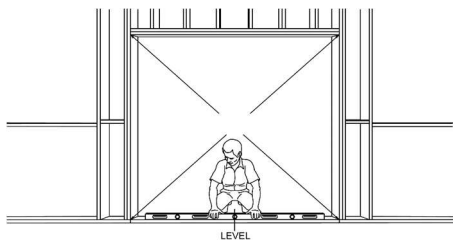

Figure 1

1.0 FRAME ASSEMBLY:

1.1 The frame consists of 4 main vinyl members:

1. Header Track
2. Sill Track
3. Left-hand Jamb
4. Right-hand Jamb

1.2 All main frame members are machined so that they may be assembled in only one way. Lay out framing members as shown in the diagram.

1.3 Using the #8 x 2" (16) screws provided; fasten the header and sill to the jambs as shown, make sure the screws are drawn tight.

1.4 It is recommended if the foam pad is compromised or missing; apply a 1/8" bead of silicone to the top of the sill at the jamb joint
And across the jamb lip. Apply to the left and right jamb joints along the top edge of the sill & jamb joints.

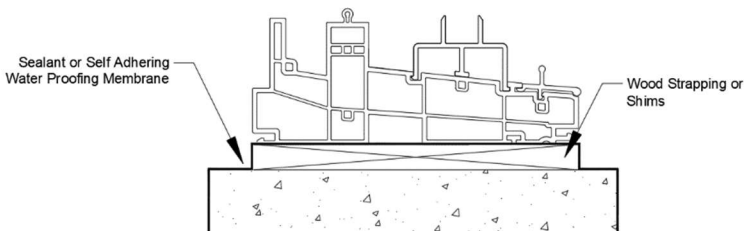

Figure 2

2.0 FRAME INSTALLATION:

2.1 The main frame is always installed with the sill sloping to the outside.

2.2 Apply a heavy continuous bead of high-quality Butyl Acoustical Sealant or Self Adhered Water Proofing Membrane to the concrete slab or sub-floor material below the sill for the entire width and depth of the sill. Then Carefully insert the frame into the opening as shown.

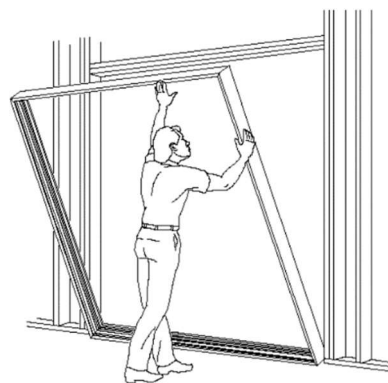

Figure 3

2.3 Center the door frame within the rough opening leaving equal clearance at both jambs.

2.4 The sill must be installed level and uniformly supported from end to end and from front to back. Use a level and use solid shims (every 16") if necessary to compensate for unevenness in the opening. Use brackets or angles that do not puncture the top of the sill if possible. If the use of screws cannot be avoided through the sill (**NOT RECOMMENDED**), ensure they are back sealed and covered with sealant. They must be waterproof. Apply sealant to all fasteners in the sill.

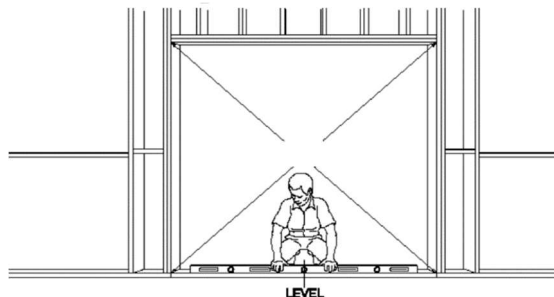

Figure 4

2.4a At a minimum, the header must be anchored at each meeting or parting rail and within 6" of each corner. The jambs must be anchored 6" from each corner and within 6" from the top and bottom of the lock keeper for the operating side, but more for oversized doors.

2.4b For security it is recommended to install solid blocking between the jamb and the surrounding structure at the lock keeper location and to put installation screws through and directly above and below the keeper. All screws must engage the surrounding structure a minimum of 1".

2.4c It is the responsibility of the installer to drill the installation holes. Anchor the fixed side jambs within 6" of the center of the jamb.

2.4d Set shims behind the frame installation holes to make the mainframe plumb and square then temporarily fasten the frame to the surrounding structure. Using a level and measuring diagonally, check that the frame is straight, plumb and square, adjust the shims if necessary, and securely fasten all screws.

3.0 INSTALLING THE FIXED PANEL

3.1 From the inside of the building, lift the fixed panel into the center track of the frame header and carefully lower onto the sill as shown. The wool pile at the meeting rail should now be facing the inside of the building.

3.2 The fixed panel should be completely level with the sill, no gaps should be apparent between the sill and the bottom of the fixed panel.

3.3 Push the fixed panel securely and completely into the jamb.

3.4 You may need to use silicon spray along the sill and up the jamb to fully engage the fixed panel. If additional assistance is required use a spreader bar to push the fixed panel firmly against the jamb.

3.5 First fasten the fixed panel bumper to the top and bottom of the fixed panel with **#8x3/4"** (4) self-drilling screws (as shown #1).

3.6 Now fasten the fixed panel bumper to the top and bottom of the jamb with **#8x1-1/4"** (4) screws (as shown #2)

3.7 Now place screw caps over all the screw heads of the fixed panel bumpers.

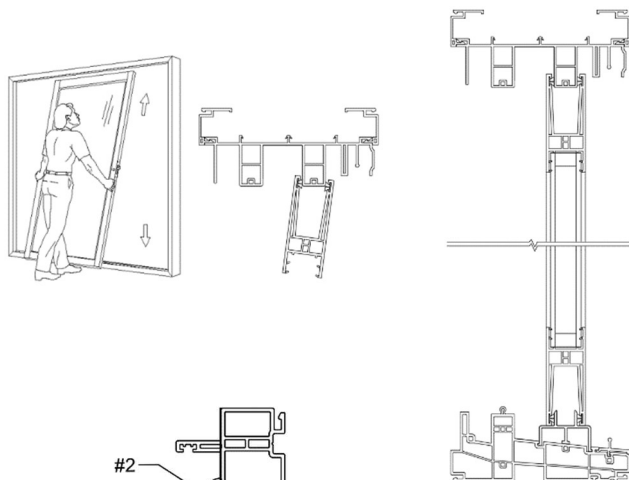

Figure 5

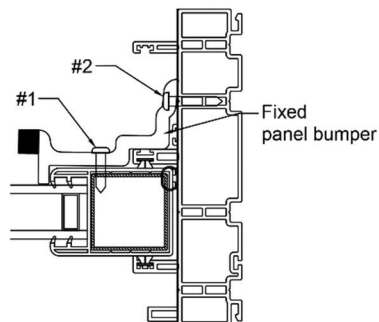

Figure 6

4.0 INSTALLING SILL PAD

4.1 Remove the adhesive backer that is on the sill pad. Install the sill pad (Figure 7) tightly towards the sill track and directly against the panel support. Seal the perimeter of the sill pad with silicone sealant.

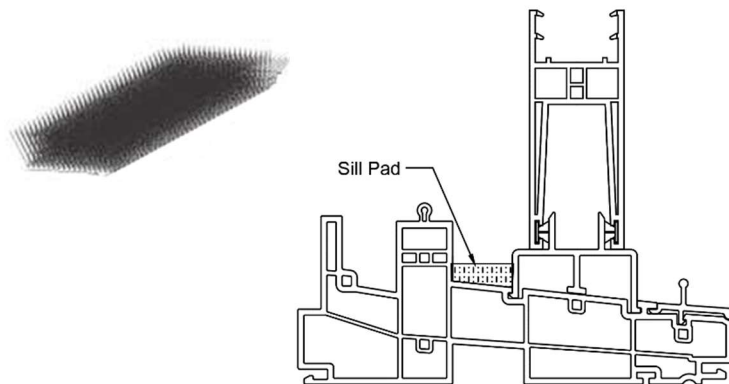

Figure 7

5.0 INSTALLING DUAL TANDEM ROLLERS

5.1 Fasten dual tandem rollers into bottom rail of operating panel. Use #8x3/4" pan head tapping screw. Be sure to fasten rollers one (1") inch from ends of rails. As shown.

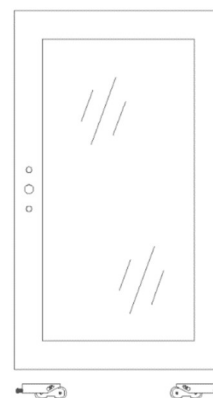

Figure 8

6.0 INSTALLING THE OPERATING PANEL

6.1 Lift the operating panel into the inside track of the frame header and carefully lower onto the roller track of sill as shown.

6.2 Using a handheld screwdriver (#2-Robertson or #2-Phillips), adjust the rollers up or down to align the top of the weather stripping on the inside of the bottom rail to be riding approximately 1/16" to 1/8" below the top edge of the sill as shown.

Turn the screw clockwise to raise the panel or counterclockwise to lower the panel as shown.

NOTE: Clearview recommends lifting the panel slightly when adjusting the wheels for ease of turning and to ensure against stripping the adjustment mechanism.

Slide the panel in the closing direction to within 1/4" of the jamb. Visually, the gap between the panel and the jamb should be uniform from top to bottom. If not, adjust the panel downward at one corner until the panel aligns to the jamb. If the jamb is bowed, remove installation screws, adjust the shims, and re-fasten.



Figure 9

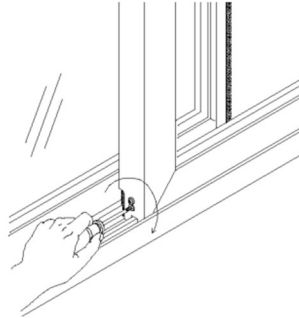

Figure 10

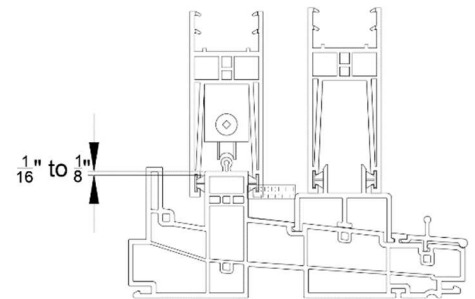

Figure 11

7.0 MORTISE LOCK HANDLE AND KEEPER INSTALLATION

7.1 All hardware for locking the door is packaged separately. Follow the instructions enclosed in the hardware package for the hardware option provided. Only after the panels have been adjusted as previously noted, attach the operating mechanism, handles, and lock keeper as outlined in the door hardware instruction sheet.

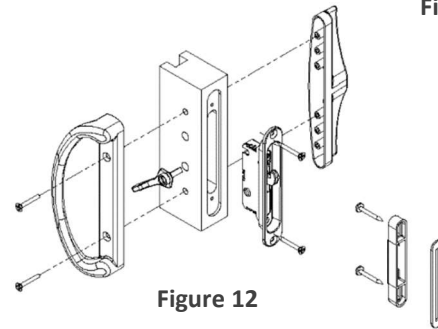

Figure 12

NOTE: Install the screws through the centre of the slots in the keeper to allow for future vertical adjustments if necessary.

8.0 INSTALLING ANTI-LIFT BLOCK

8.1 The anti-lift block is installed in the header portion of the door frame above the operating panel. This is a security precaution to avoid intruders from lifting the panel while in the locked position. Slide the door to the full opened position; place the anti-lift into the centre header section where the panels interlock as shown.

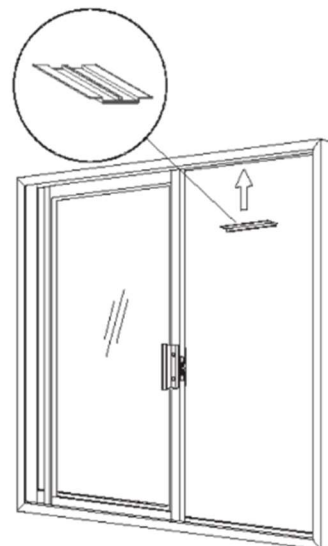

Figure 13

9.0 INSTALLING THE SCREEN PANEL

9.1 Before installing the screen, back-off all four wheels by turning the adjustment screws counter-clockwise as shown.

9.2 Insert the screen in the outside track of the frame header, swing the bottom of the screen towards the sill and snap the rollers over the sill screen track as shown.

9.3 Slide the screen in the closing direction to within 1/4" of the jamb. Visually, the gap between the screen and the jambs should be uniform from top to bottom.

9.4 Using a screwdriver (#2-Robertson or #2-Phillips) adjust the rollers on the bottom of the screen up (clockwise) or down (counter-clockwise) to align the screen as shown above. Adjust the top rollers just enough to snug the screen in the top track and allow easy rolling.

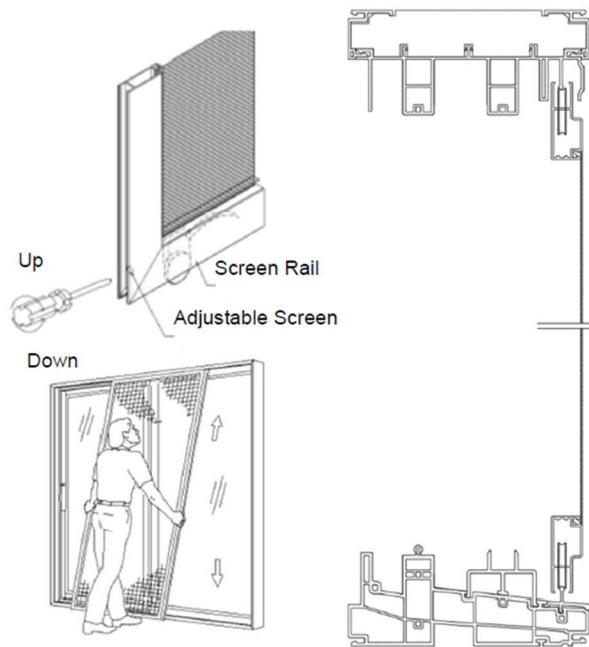

Figure 14

10.0 CAULKING/INSULATION/FINISHING

10.1 Use high quality exterior sealant that is compatible with PVC surfaces of the sliding door and the surrounding structure. (Check the application with your sealant supplier.) It is important that all PVC surfaces to be caulked are free of dust, dirt and grease and are well cleaned. Depending on the sealant being used, a primer may also be necessary.

NOTE: DO NOT caulk over the weep(s) when caulking across the sill.

10.2 Insulate the perimeter of the door frame between sub-structure and door frame using low expansion spray foam insulation. Do NOT overspray foam as this could cause deformation of the frame. Or use loose fill batt insulation.

10.3 Finish interior and exterior trim as required.

Visit Our Web Site @ www.clearview.on.ca



45 Fenmar Drive
 Toronto, Ontario Canada M9L1M1
 Toll: 1-888-253-2739
 Tel: 416-745-6666
 Fax: 416-745-3711
 E: sales@clearview.on.ca