

Assembly and Installation Guide of 7700 Series – 2 Panel Sliding Door

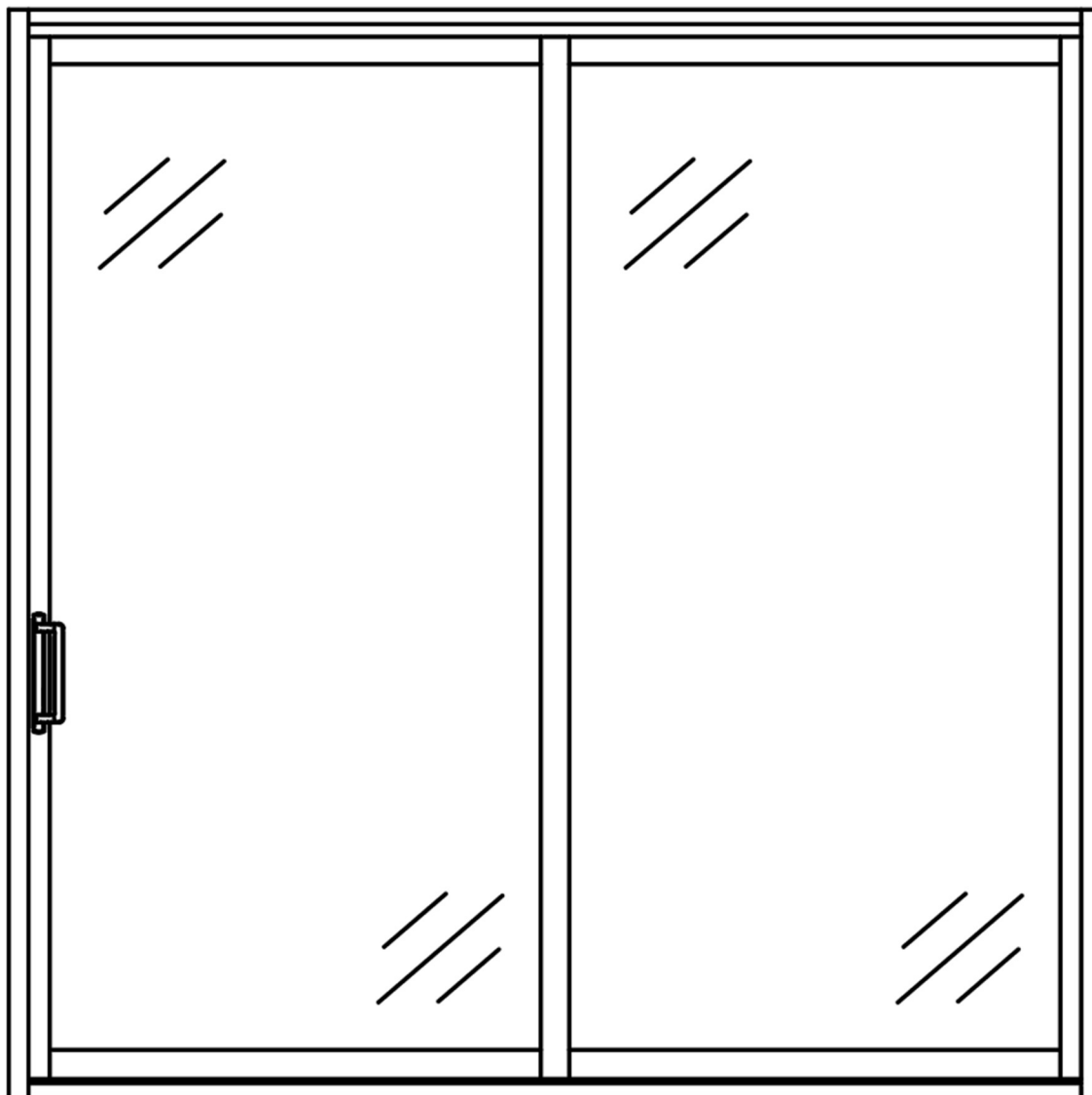

Outside View Elevation

NOTICE

READING THESE INSTRUCTIONS FIRST AND FOLLOWING THE PROCEDURES IN PROPER SEQUENCE

WILL REDUCE COSTLY MISTAKES AND WASTED TIME.







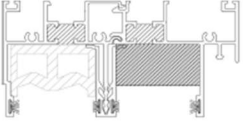

	<p>Main Frame Header Aluminum frame extrusion. Used for the header. Includes 1 neoprene foam block on top of the fixed panel (factory installed).</p>	<p>1 Pc</p>		<p>#8X1-1/2" Pan Head Screws For main frame assembly. Frame installation screws (not supplied) used is dependent on door size. Screws must be at least 2-1/2".</p>	<p>18 Pcs</p>															
	<p>Main Frame Jamb (Left and Right) Aluminum frame extrusion. Used for the jambs (left and right sides). Includes Butyl foam gaskets (factory installed).</p>	<p>1 Set</p>		<p>#8x3/4" Pan Head Self-Drilling Screws 4-Screws are used to attached the fixed panel clip (4 screws/clip) to the main frame and the fixed panel. 1-Screw for the anti-lift block.</p>	<p>8 Pcs (OX / XO) 16 Pcs (OXO / OXXO) 0 Pcs (XOO / OOX)</p>															
	<p>Main Frame Sill Aluminum frame extrusion.</p>	<p>1 Pc</p>		<p>Fixed Panel Clip The fixed panel clip is installed at the top and bottom of the frame and fixed panel. See labels on the frame and sash for location.</p>	<p>2 Pcs (OX / XO) 4 Pcs (OXO / OXXO) 0 Pcs (XOO / OOX)</p>															
	<p>Sill Cover Aluminum frame extrusion.</p>	<p>1 Pc (OX / XO) 2 Pcs (OXO) 2 Pcs (OXXO)</p>		<p>Fixed Panel Clip Cover The Fixed panel clip cover goes onto the fixed panel clip.</p>	<p>2 Pcs (OX / XO) 4 Pcs (OXO / OXXO) 0 Pcs (XOO / OOX)</p>															
	<p>Mortise Lock Handle & Keeper - Square Interior & exterior handle, keeper allows operating frame to lock with main frame. Hardware kit included.</p>	<p>1 Set</p>		<p>Pocket Cover (Optional)</p> <table border="1" data-bbox="1122 1077 1523 1150"> <thead> <tr> <th></th> <th>OX / XO</th> <th>OXO</th> <th>XOO / OOX</th> <th>OXXO</th> </tr> </thead> <tbody> <tr> <td>Exterior</td> <td>2 Pcs</td> <td>0 Pcs</td> <td>4</td> <td>1</td> </tr> <tr> <td>Interior</td> <td>1 Pc</td> <td>2 Pcs</td> <td>0</td> <td>2</td> </tr> </tbody> </table>		OX / XO	OXO	XOO / OOX	OXXO	Exterior	2 Pcs	0 Pcs	4	1	Interior	1 Pc	2 Pcs	0	2	
	OX / XO	OXO	XOO / OOX	OXXO																
Exterior	2 Pcs	0 Pcs	4	1																
Interior	1 Pc	2 Pcs	0	2																
	<p>Operating Panel Stop The operating panel stop is installed in the header portion of the door frame in front of the fixed panel at the left or right jamb depending on the operation of the door.</p>	<p>1 Pc</p>	<p>Adhesive Strip</p> 	<p>Closed Cell Foam Block At interlock on fixed panel.</p>	<p>1 Pc</p>															

Table 1

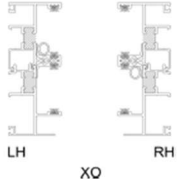
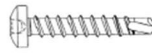
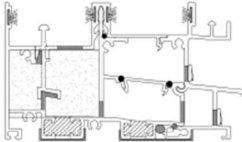
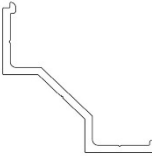
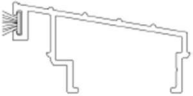
OXXO (Only) (In Addition)



	<p>Filler Block Set</p> <p>White in / black out or Black in / white out.</p>	<p>1 Set</p>
<p>Weather Strip OXXO Only</p>  <p>Sill Cover</p>	<p>Weather strip with fin 1" x 3/8" -Sill deflector.</p>	<p>1 pc</p>
	<p>Closed cell foam block 1" x 1 1/2" x 1/2", at base mullion.</p>	<p>1 Pc</p>

Table 2

2-PANEL DOOR – INSTALLATION INSTRUCTIONS

GENERAL:

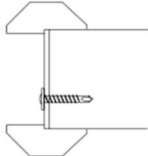
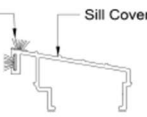
Door elevations shown in these instructions are as viewed from the outside.

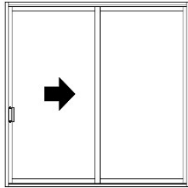

"XO" DOOR

'X' denotes the active or operating panel(s).
'O' denotes the inactive or fixed panel(s).

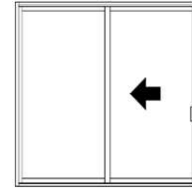

"OX" DOOR

All 2-panel doors between 72" to 80" high are fully reversible. The locking hardware on the operating panel is located at the mid-point of the panel unless otherwise requested. For 3 and 4 panel doors or alternate locking hardware options, refer to the supplemental instructions sheet.

A) ROUGH OPENING PREPARATION:

The rough opening should be made 1/2" wider and 3/8" higher than the actual door frame size (Refer to the chart for frame sizes). The sill or base of the opening must be solid, level and of sufficient width and depth to support the entire door sill in a continuous and uniform manner. It is important that the opening be plumb and square as the door will not perform to its potential if installed into an improperly prepared opening.

7700 Series Technical Specifications

Configuration	Size	Frame Size (in)		Rough Opening	
		Width	Height	Width	Height
XO or OX	5068	59-1/2	79-1/2	60	79-7/8
XO or OX	6068	71-1/2	79-1/2	72	79-7/8
XO or OX	8068	95-1/2	79-1/2	96	79-7/8
OXO	7668	90-5/8	79-1/2	91-1/8	79-7/8
XOO or OOX	7668	86-7/8	79-1/2	87-3/8	79-7/8
OXO	9068	108-5/8	79-1/2	109-1/8	79-7/8
XOO or OOX	9068	104-7/8	79-1/2	105-3/8	79-7/8
OXO	12068	144-5/8	79-1/2	145-1/8	79-7/8
XOO or OOX	12068	140-7/8	79-1/2	141-9/16	79-7/8
OXXO	10068	116-7/8	79-1/2	117-3/8	79-7/8
OXXO	12068	140-7/8	79-1/2	141-3/8	79-7/8
OXXO	16068	188-7/8	79-1/2	189-3/8	79-7/8

Table 3

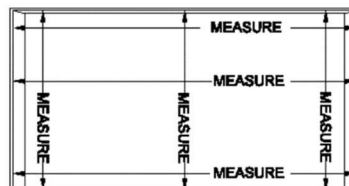
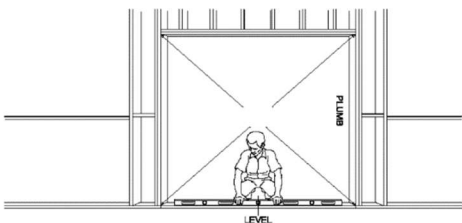

1.0 FRAME ASSEMBLY:

1.1 The frame consists of 4 main thermally broken aluminum members:

1. Header Track
2. Sill Track
3. Left-hand Jamb
4. Right-hand Jamb

1.2 All main frame members are machined so that they may be assembled in only one way. Lay out the framing members as shown in the diagram (figure 1).

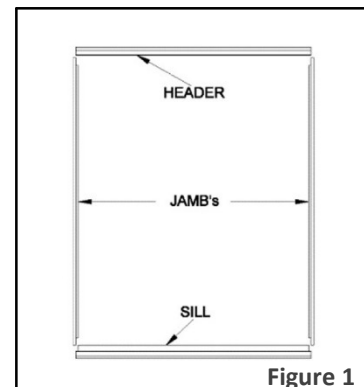

Figure 1

1.3 Prior to assembling the frame, remove the paper backer from factory installed Butyl tape at the ends of the header, sill and the jambs (top only)

1.4 Using the #8 x 1-1/2" screws provided; fasten the header and sill to the jambs as shown, make sure the screws are drawn tight.

1.5 If the butyl pad is compromised or missing, apply a 1/8" bead of silicone from the bottom of the track to the top of the sill at the jamb joint and across the jamb lip. Apply to the left and right jamb joints.

2.0 FRAME INSTALLATION:

2.1 The main frame is always installed with the sill sloping to the outside.

2.2 Apply a heavy continuous bead of good quality caulking/Butyl sealant or Self-Adhesive Water Proofing Membrane (recommended) under the outside lip of the sill and insert the main frame into the opening as shown (figure 2).

2.3 Center the door frame within the rough opening leaving equal clearance at both jambs (figure 3).

2.4 The sill must be installed level and uniformly supported from left side to right side and from inside to outside. Use a level and use solid shims made of composite pvc or wood material (every 16") if necessary to compensate for unevenness in the opening (Figure 2). Use brackets or angles that do not puncture the top of the sill if possible but if the use of screws cannot be avoided, ensure they are back sealed and covered with sealant. They must be waterproof. Apply sealant to all fasteners.

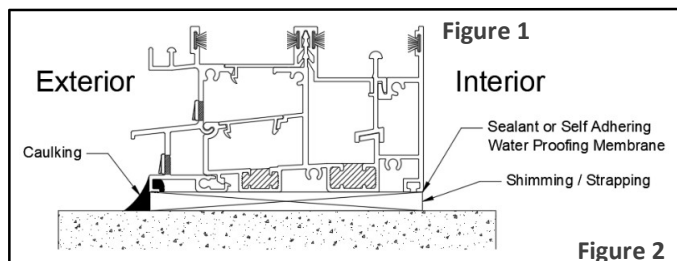

Figure 2

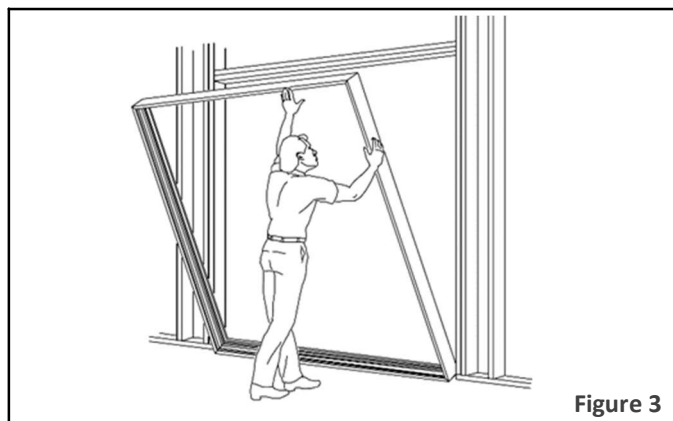

Figure 3

2.5 At a minimum, the header must be anchored above each meeting rail and location within 6" of each corner. The jambs must be anchored 6" from each corner and within 6" from the top and bottom of the lock keeper for the operating side, but more for oversized doors. Clearview strongly recommends that fasteners are installed in both the inner and outer tracks on the header and jambs.

2.5a For security it is recommended to install solid blocking between the jamb and the surrounding structure at the lock keeper location and to put installation screws through and directly above and below the keeper. All screws must engage the surrounding structure a minimum of 1".

2.5b It is the responsibility of the installer to drill the installation holes. Anchor the fixed side jambs within 6" of the center of the jamb.

2.5c Set shims behind the frame installation holes to make the mainframe plumb and square then temporarily fasten the frame to the surrounding structure. Using a level and measuring diagonally, check that the frame is straight, plumb and square, adjust the shims if necessary, and securely fasten all screws.

2.5d Once all shimmed, measure each diagonal direction and ensure they are within 1/4" tolerance, if difference is greater than 1/4", please adjust frame to ensure within 1/4".

2.6 NOTE: For installations in high-wind areas, attaching to window systems, or when using oversized doors, the quantity, size, type and engagement of the fasteners and the supporting shims should be as follows; Additional structural engineering consultation may be required

2.6a Minimum #8 x 3" screw fastener or better at 6" from end and every 30" spaced out at even intervals for the jamb and header. Fasten 2 screws at each point, one in the exterior channel and the other in the interior channel. All screws must be supported with composite pvc or wood shimming material to allow for proper leveling.

2.6b In the case of attaching within a window system, it is the responsibility of the contractor to determine if the surrounding structure is supportive of the door system.

3.0 INSTALLING THE FIXED PANEL

3.1 From the outside of the building, lift the fixed panel into the furthest away/exterior track of the frame header and carefully lower onto the sill (figure 4). The wool pile at the meeting rail should now be facing the inside of the building.

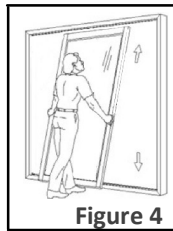

Figure 4

3.2 The fixed panel should be completely level with the sill; no gaps should be apparent between the sill and the bottom of the fixed panel.

3.3 Push the fixed panel securely and completely into the jamb. You may need to use silicone spray along the sill and up the jamb to fully engage the fixed panel. If additional assistance is required use a spreader bar to push the fixed panel firmly against the jamb.

3.3 INSTALLATION WITH PANEL CLIPS:

3.3a First fasten the fixed panel clip to the vertical rail of the fixed panel with #8x3/4" screws (as shown #1, figure 6) as indicated by the predrilled holes on the fixed pull rail. One at top and one at bottom.

3.3b Now fasten the fixed panel clip to the jamb with #8x3/4" screws (as shown #2, figure 6) as indicated. Now place fixed panel clip covers over the fixed panel clips.

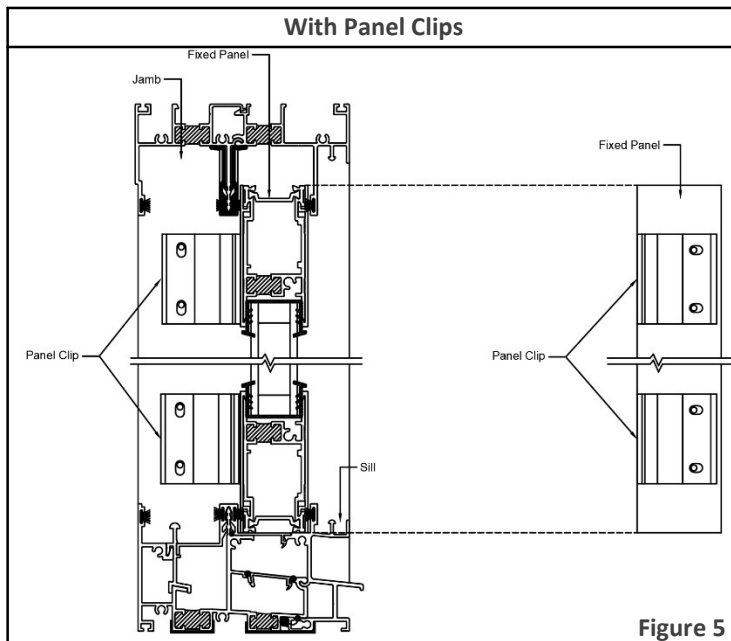

Figure 5

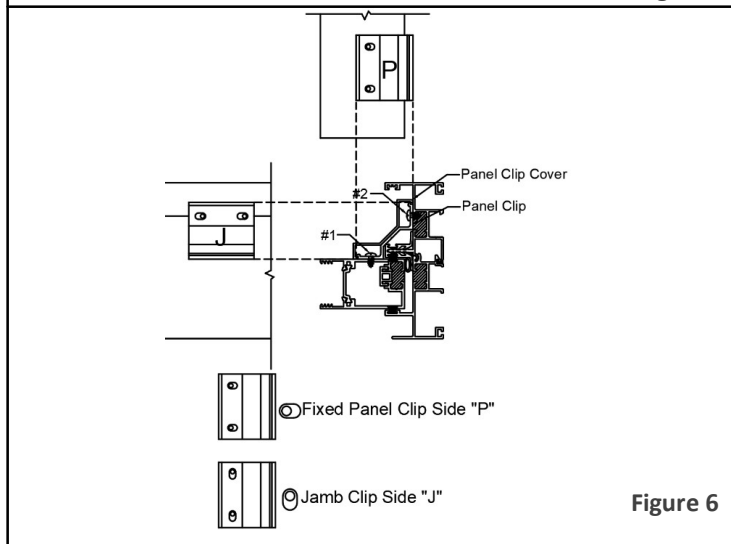

Figure 6

3.4 INSTALLATION WITH JAMB POCKET COVERS (OPTIONAL):

Interior Pocket Cover

3.4a Install Sill Cover (step 4.0).

3.4b Drill 1/8" holes (4) through jamb center leg into fixed rail (figure 7). Note 4 holes have been factory predrilled at top and bottom at jamb center leg. Holes are roughly 1/2" from each end, 1 1/4" centre to centre distance, 3/16 diameter holes.

3.4b Install #8 x 1 1/4" self drilling countersunk screws through aluminum jamb into fixed sash as shown (figure 8).

3.4c The snap leg on interior pocket cover has been pre-notched from factory (figure 9). Should screws be installed outside of the location noted, pocket cover will not snap.

3.4d Engage pocket cover leg into interior jamb weatherstrip channel. Apply pressure to pocket cover starting at top working downward to sill (figure 10)

Exterior Pocket Cover

3.4c Repeat the previous step but this time into the exterior jamb weatherstrip channel. Apply pressure to pocket cover starting at top working downward to sill.

3.4C Follow the same process for the exterior jamb pocket at the header. Press the cover into the header in an angle until it snaps in.

With Jamb Pocket Covers (Optional)

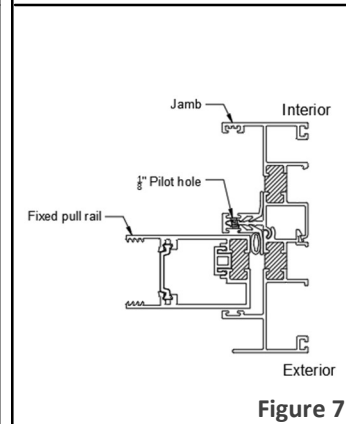

Figure 7

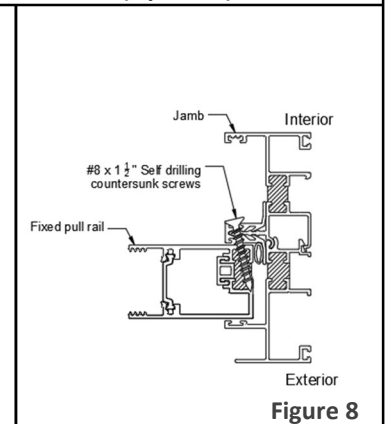

Figure 8

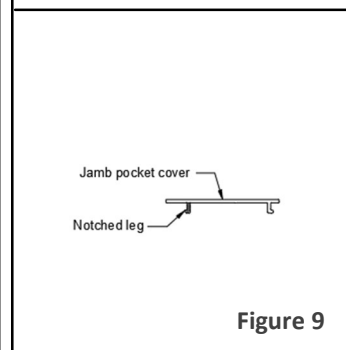

Figure 9

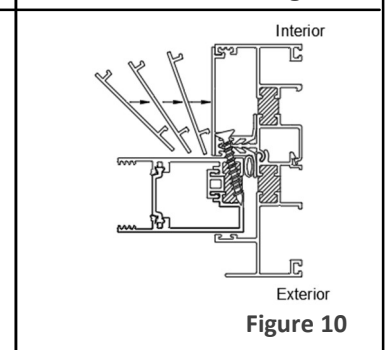

Figure 10

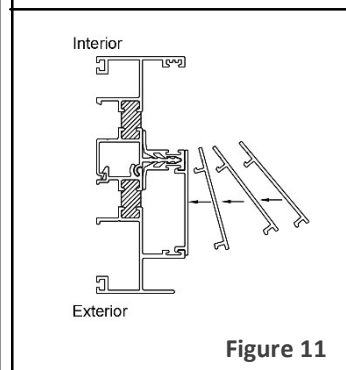

Figure 11

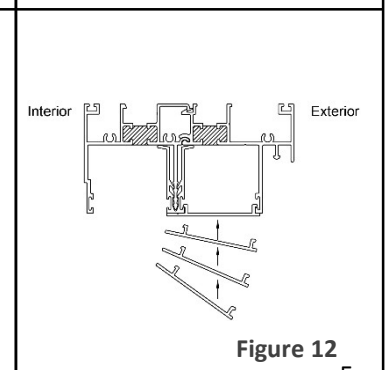

Figure 12

3.5 Install the closed cell foam (supplied in kit) above the fixed panel. It should be tight to all edges and past the interlock by at least 1/4" (figure 13). Install the second close cell foam on top of the notch of the fixed interlock (figure 14).

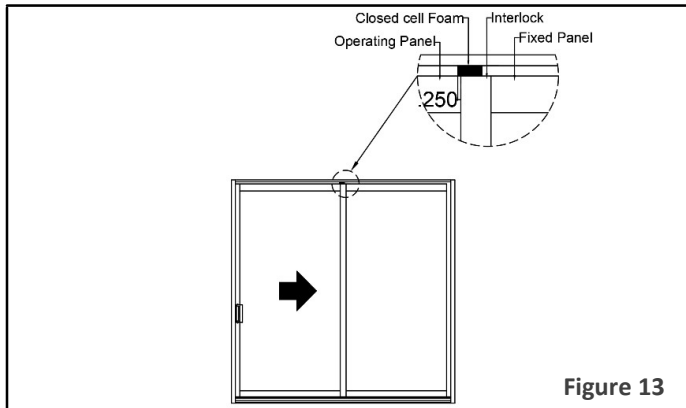

Figure 13

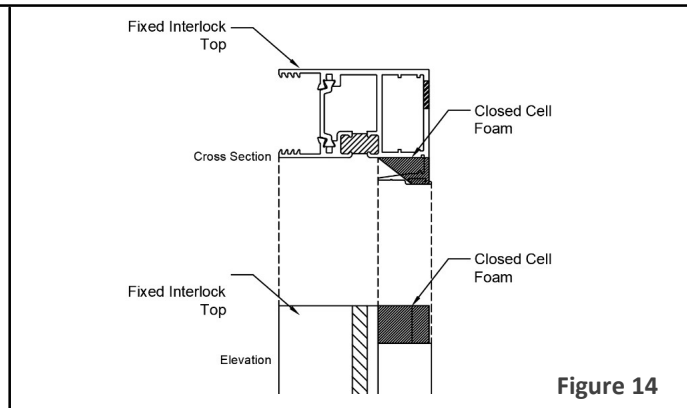

Figure 14

3.6 With the fixed panel completely secured, apply a 1/8" bead of silicone starting from the interior edge of the bottom fixed interlock towards the exterior all the way (figure 15 & 16).

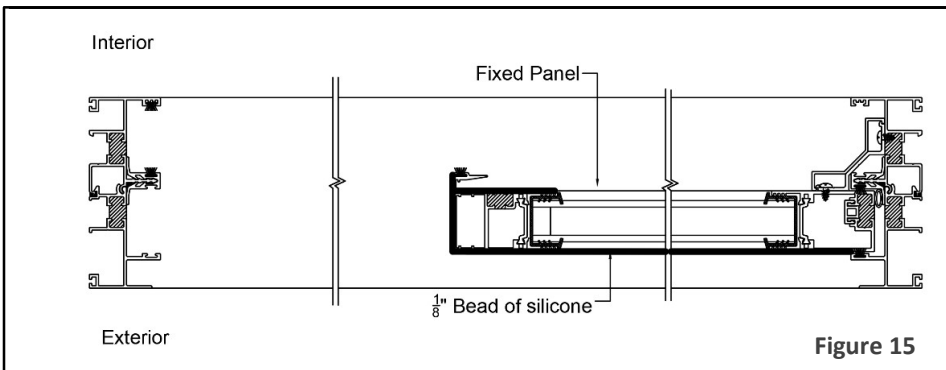

Figure 15

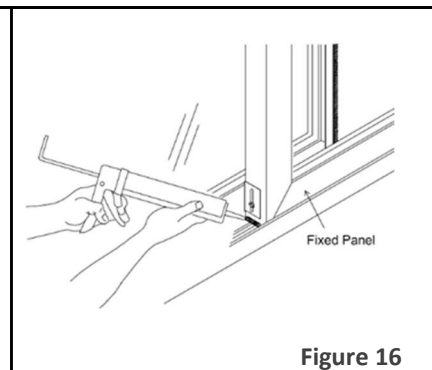

Figure 16

4.0 Sill Cover Installation

4.1 Angle sill cover bottom into jamb first, tight against foam and slowly lower another end down (figure 17).

4.2 Rotate sill cover on an angle and place it inside of the exterior sill track.

4.3 Apply pressure on top of the sill cover until the piece snap into place.

4.4 Apply clear silicone on the exterior face of the sill cover, and on the ends towards the jamb and fixed panel (figure 18).

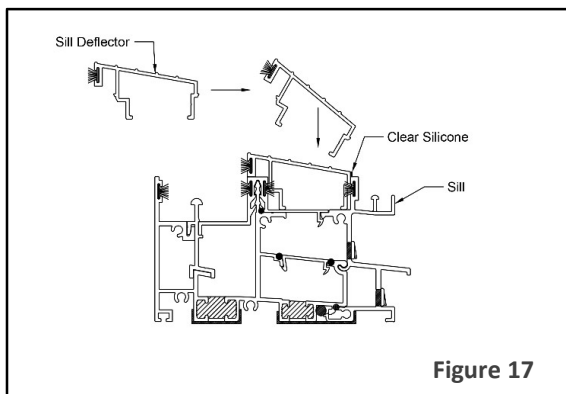

Figure 17

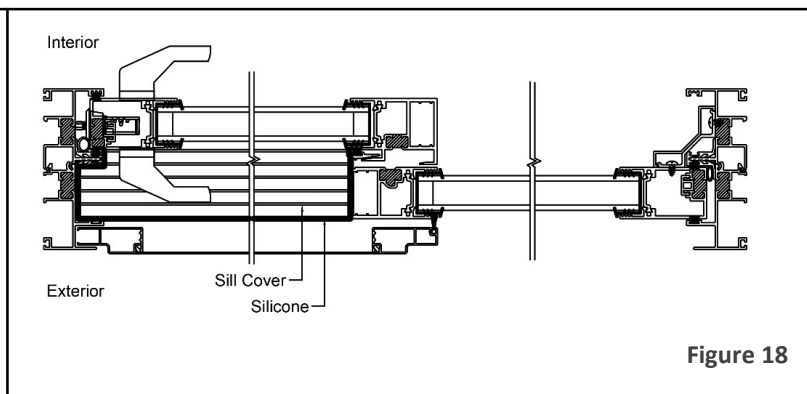

Figure 18

5.0 INSTALLING THE OPERATING PANEL



Figure 19

5.1 Lift the operating panel into the inside track of the frame header and carefully lower onto the roller track of sill as shown.

5.2 Using a handheld screwdriver (#2-Robertson or #2- Phillips), adjust the rollers up or down to align the top of the weather stripping on the outside of the bottom rail to be riding approximately 1/16" to 1/8" below the sill frost bar. Turn the screw clockwise to raise the panel or counterclockwise to lower.

NOTE: Clearview recommends lifting the panel slightly when adjusting the wheels for ease of turning and to ensure against stripping the adjustment mechanism. Slide the panel in the closing direction to within 1/4" of the jamb. Visually, the gap between the panel and the jamb should be uniform from top to bottom. If not, adjust the panel downward at one corner until the panel aligns.

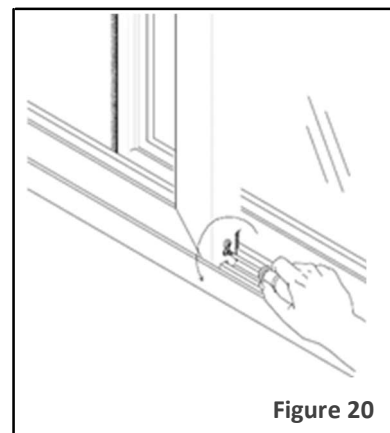

Figure 20

6.0 MORTISE LOCK HANDLE AND KEEPER INSTALLATION

6.1 All hardware for locking the door is packaged separately. Follow the instructions enclosed in the hardware package for the following hardware option provided. Only after the panels have been adjusted as previously noted, attach the operating mechanism, handles, and lock keeper as outlined in the door hardware instruction sheet.

6.2 Mortise Lock: **Standard for all doors** (Not available for OXXO doors). Attach the operating mechanism and handles to the lock rail as shown. Ensure that the striker hook is facing upwards.

NOTE: Install the screws through the centre of the slots in the keeper to allow for future vertical adjustments if necessary. the jamb. If the jamb is bowed, remove installation screws, adjust the shims, and re-fasten.

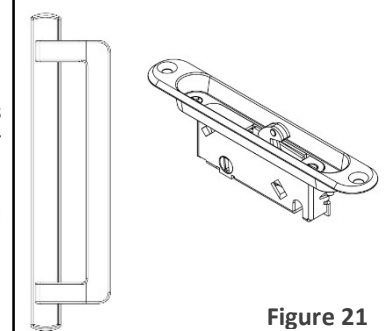

Figure 21

7.0 INSTALLING OPERABLE PANEL STOP

7.1 The panel stop bumper is installed in the header portion of the door frame in-front of the fixed panel at the far left or right (depending on operation) beside the jamb as shown (Figure 22).

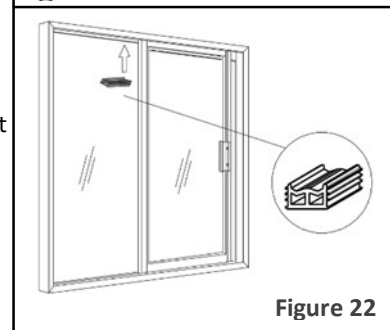

Figure 22

8.0 INSTALLING THE SCREEN PANEL

8.1 Before installing the screen, back-off all four wheels by turning the adjustment screws counter-clockwise as shown.

8.2 Insert the screen in the outside track of the frame header, swing the bottom of the screen towards the sill and snap the rollers over the sill screen track as shown. Glazing bar or fat screwdriver should be used to snap wheels onto track. Slide the screen in the closing direction to within 1/4" of the jamb. Visually, the gap between the screen and the jambs should be uniform from top to bottom.

8.3 Using a screwdriver (#2-Robertson or #2-Phillips) adjust the rollers on the bottom of the screen up (clockwise) to align the screen with a 1/8" gap from bottom of screen to bottom of sill (Figure 24). Adjust the top rollers just enough to snug the screen in the top track and allow easy rolling.

8.4 Install interior locking handle and exterior handle to the screen.

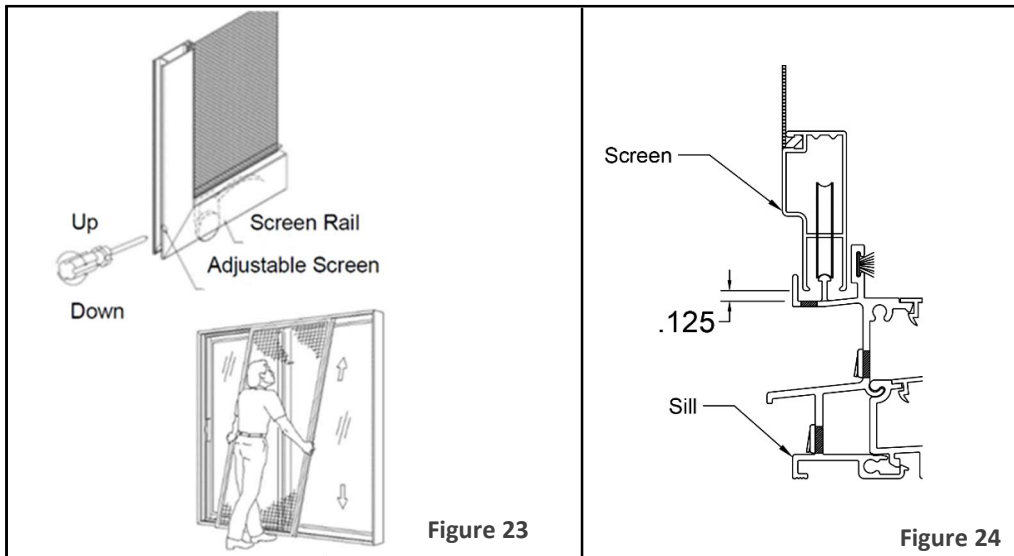

9.0 CAULKING/INSULATION/FINISHING

9.1 Use good quality building sealant that is compatible with aluminum surfaces of the sliding door and the surrounding structure. (Check the application with your sealant supplier.) It is important that all aluminum surfaces to be caulked are free of dust, dirt and grease and are well cleaned. Depending on the sealant being used, a primer may also be necessary.

NOTE: DO NOT caulk over the drain flaps when caulking across the sill.

10.0 7700 Series 2 Panel Door Configuration

10.1 General Parts Location

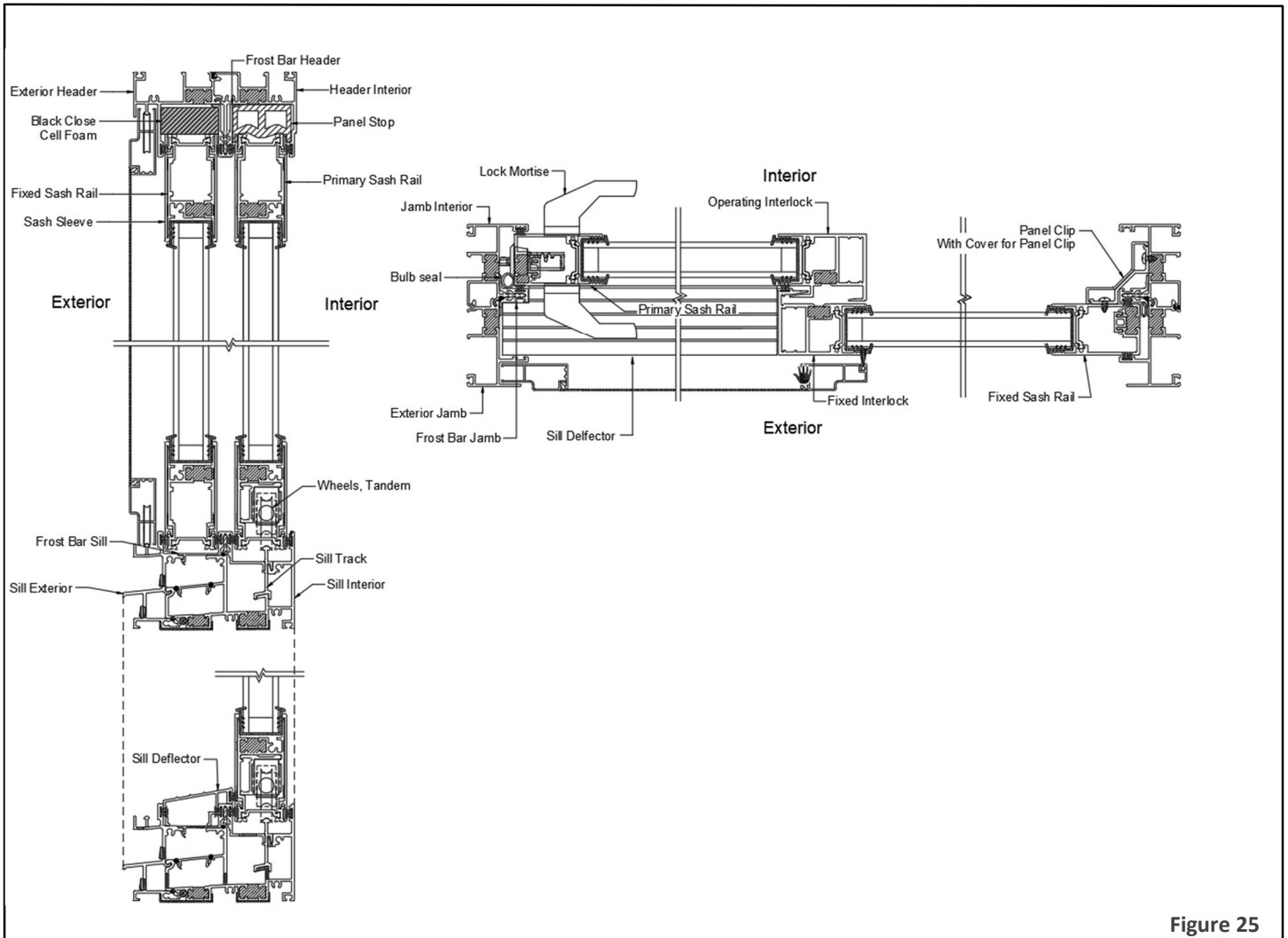

Figure 25

Visit Our Web Site @ www.clearview.on.ca

CLEARVIEW
INDUSTRIES LTD

45 Fenmar Drive
Toronto, Ontario Canada M9L1M1
Toll: 1-888-253-2739
Tel: 416-745-6666
Fax: 416-745-3711
E: sales@clearview.on.ca