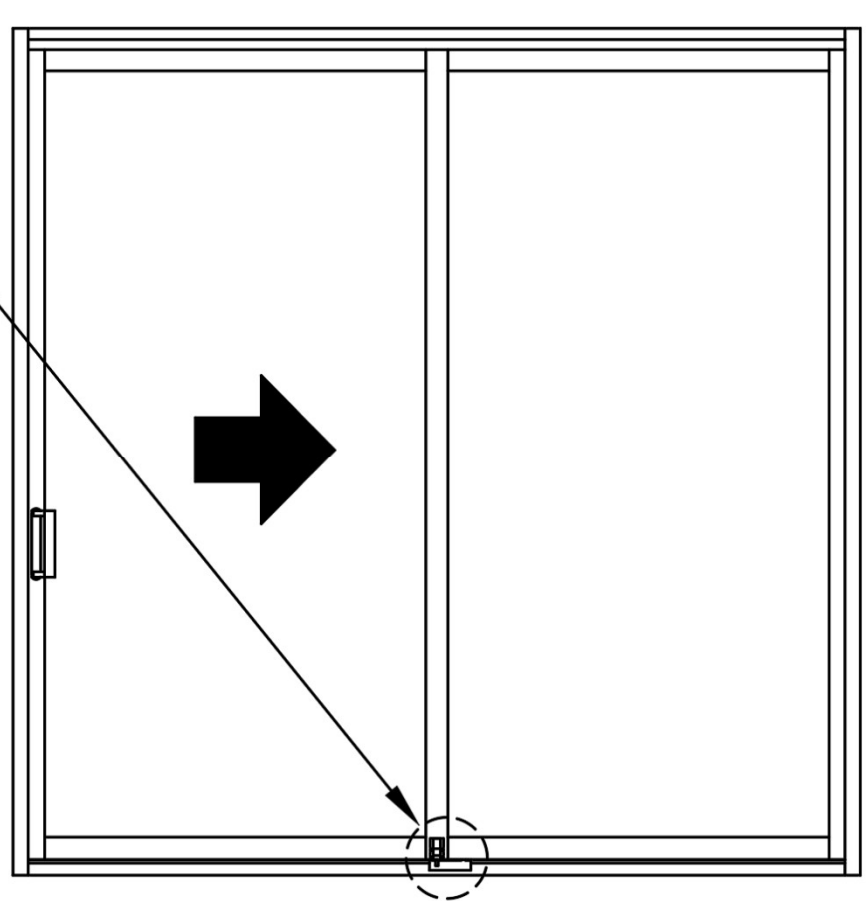
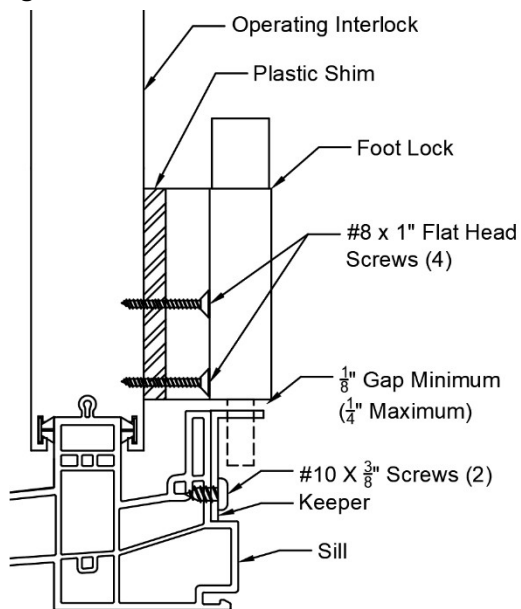

**Figure 2 – Aluminum Door**



**Figure 1 - Aluminum Sliding Door - Interior View**



**Figure 3 – 6200/6500 Series Door**

- Close the door (in a locked position).
- Extend the bolt down until it locks.
- Position the keeper behind the sill, top level to track, so that slot "A" is on the center of interlock (see diagram on **Figure 1**), then mark and use two #8 x 3/8" screws to mount the keeper.
- Position the lock onto the center of operating interlock of slider, and position the bolt as close to as possible, but without touching the bottom sill.
- Mark holes and mount the lock with the four #8 x 1" screws provided.
- Door opening can be limited to approx. 3" simply by engaging the bolt onto the second slot at position "B" (see diagram on **Figure 1**) of keeper.
- On 6200/6500 Series Sliding Doors, place the plastic shim provided in between the foot lock and operating interlock (see **Figure 3**).

Visit Our Web Site @ [www.clearview.on.ca](http://www.clearview.on.ca)

**CLEARVIEW**  
INDUSTRIES LTD

45 Fenmar Drive  
Toronto, Ontario Canada M9L1M1  
Toll: 1-888-253-2739  
Tel: 416-745-6666  
Fax: 416-745-3711  
E: [sales@clearview.on.ca](mailto:sales@clearview.on.ca)